

DATASHEET

CAPTURE MODULE 1000 HIGH

General description

The Capture Module (CM) 1000 High from Technica Engineering is an active tap device designed to capture 100/1000Base-T1 traffic of up to 6 point-to-point 100/1000BASE-T1 connections (12 ports in total). The received data is captured and HW timestamped without causing interference on the in-vehicle-network (IVN) and sent out to the data sink (e.g. data logger or PC).

Standardized logging protocol

The Capture Module encapsulates logged frames into an ethernet frame adding valuable information such as the HW timestamp, Interface ID, Counter and more in a standardized logging protocol header.

Scalable setups

Several Capture Modules can be combined and used together in the same measurement network. The built-in time synchronization feature allows to synchronize the whole measurement network with the same time base. This makes the Capture Modules very scalable and allows to add other IVN technologies to the measurement setup.



Capture Module 1000High

Application Areas

Capture Modules are designed to be used in different environments such as in the car, on a development desk or in testbenches. In order to cover these areas as best as possible, the devices allow continuous operation and a wide temperature range.

Optimized logging

Startup time is crucial in an in-vehicle-network. Therefore, the Capture Modules are developed to provide an optimized startup time to be ready to log before the ECUs are up and send data. In addition to that, the Capture Module is equipped with an internal buffer to store the first frames (sent from the ECUs), even if the data sink is not yet ready. As soon as the data sink is up and ready to receive data, all the stored data will be sent out. With the packetization and output traffic shaping feature the Capture Module can adjust the size of the logging frames and have the possibility to maintain a consistent data flow (to the logger or the test PC). This way it actively prevents forwarding of bursts. The combination of these features ensures that no frames are lost.

Configuration

The CM offers a flexible and user-friendly configuration through its built-in web server. The device webpage can be easily accessed via a standard web browser. In addition, the possibility to import/export a configuration makes it even more convenient.

Technical Data

Operating Temperature	-40°C to 75°C
Supply Voltage	6.5V to 24V DC (typ. 12V DC)
Power consumption	25 to 36 Watt
IP Protection Class	IP 20
Housing Dimensions	186 mm (W), 130,4 mm (L), 32,5 mm (H)
Weight	0.8 kg (approx.)
Interfaces	12x 100/1000BASE-T1 (MATEnet or H-MTD) 3x 1000BASE-T (RJ-45) for Config, Logging, Sync 1x 10Gbit Ethernet (SFP+) for Logging, Sync 1x 100BASE-T1 (MQS) for Config 2x Wake in/out (MQS)
Phy (in-vehicle)	MARVELL 88Q2112-A2

Features of the Capture Module 1000 High

Device Features	Configuration Webpage
	Wake-/Sleep
	Import-/Export of Configurations
	Status LEDs
	TECMP / ASAM CMP
	Status Messages
	Manual IP Configuration via Rotary Switch
	Optimized Startup + Startup Buffer
	Cascading
	Hardware Timestamping with 40ns Resolution
	Time Synchronization (gPTP/802.1AS-2011 AVnu profile or PTPv2 subset)
	Packetization
	Output Traffic Shaping
	Basic + Advanced Filtering
	Sync + Link Events
Transparency Mode	
Traffic Injection	

Use case

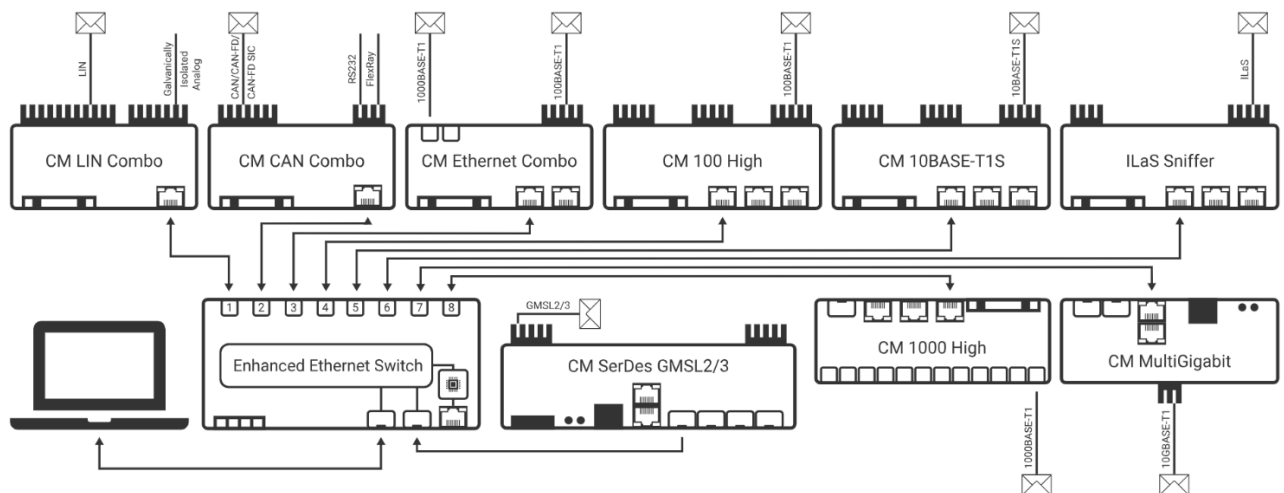

Order Information

Name	Article Number	Cable set number*
Capture Module 1000 High MATEnet	TE-1176	KS-1176
Capture Module 1000 High H-MTD	TE-1177	KS-1177

*Cable set needs to be ordered separately